

NO.	DATE	BY	CHKD.	APP.
1	11/22/2021	M. NEFF	MDN	

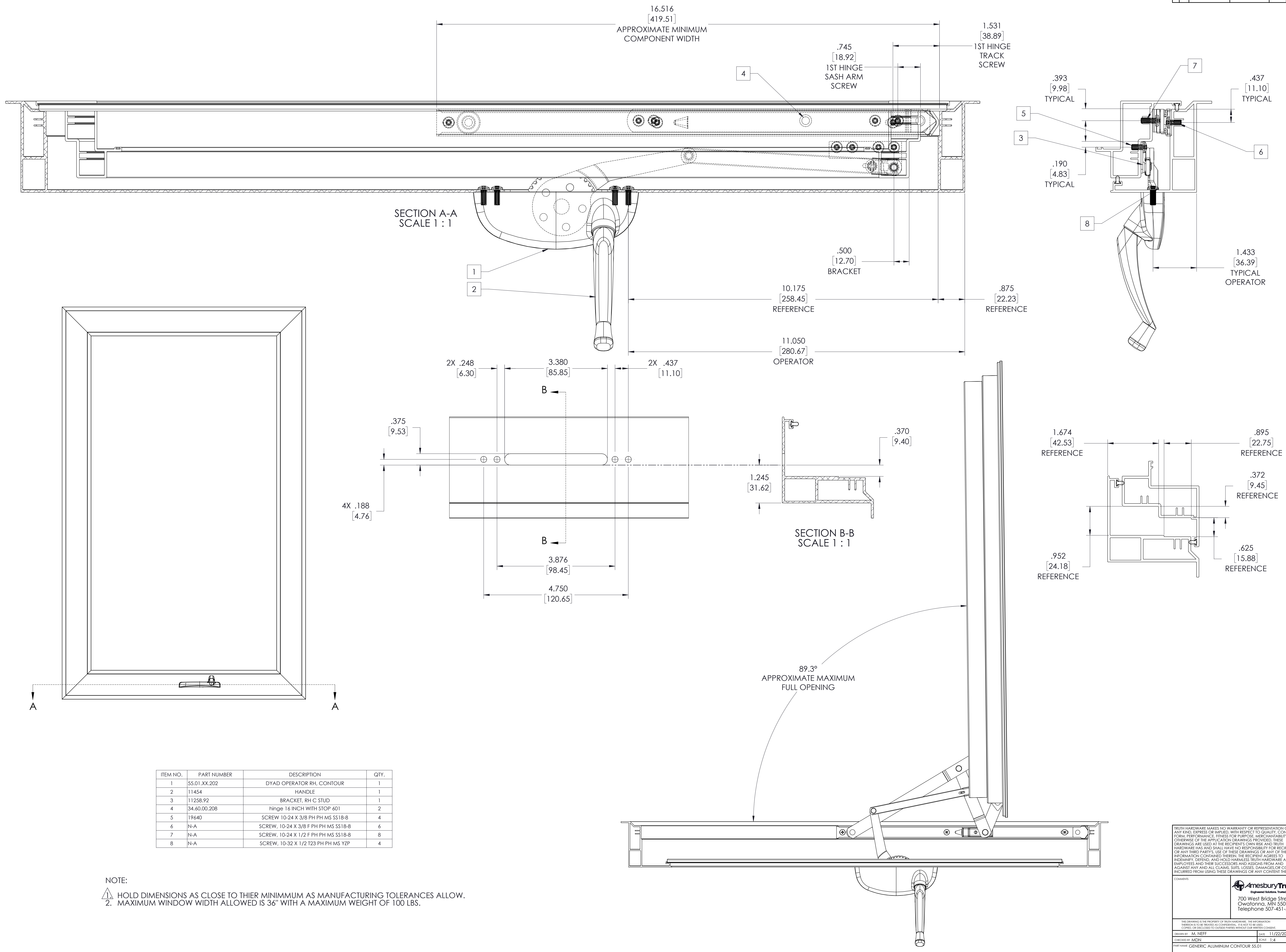

ITEM NO.	PART NUMBER	DESCRIPTION	QTY.
1	55.01.XX.202	DYAD OPERATOR RH, CONTOUR	1
2	11454	HANDLE	1
3	11258.92	BRACKET, RH C STUD	1
4	34.60.00.208	hinge 1 1/4 INCH WITH STOP .601	2
5	19640	SCREW, 10-24 X 3/8 PH PH MS SS18-8	4
6	N-A	SCREW, 10-24 X 3/8 F PH PH MS SS18-8	6
7	N-A	SCREW, 10-24 X 1/2 F PH PH MS SS18-8	8
8	N-A	SCREW, 10-32 X 1/2 T23 PH PH MS YZF	4

NOTE:
 1. HOLD DIMENSIONS AS CLOSE TO THEIR MINIMUM AS MANUFACTURING TOLERANCES ALLOW.
 2. MAXIMUM WINDOW WIDTH ALLOWED IS 36" WITH A MAXIMUM WEIGHT OF 100 LBS.

TRUTH HARDWARE MAKES NO WARRANTY OR REPRESENTATION OF ANY KIND, EXPRESS OR IMPLIED, WITH RESPECT TO QUALITY, CONTENT, FORM, PERFORMANCE, FITNESS FOR PURPOSE, MERCHANTABILITY OR OTHERWISE OF THE APPLICATION DRAWINGS PROVIDED. THESE DRAWINGS ARE USED AT THE RECIPIENT'S OWN RISK AND TRUTH HARDWARE HAS AND SHALL HAVE NO RESPONSIBILITY FOR RECIPIENTS OR ANY THIRD PARTIES. USE OF THESE DRAWINGS OR ANY OF THE INFORMATION CONTAINED THEREIN, THE RECIPIENT AGREES TO INDEMNIFY, DEFEND, AND HOLD HARMLESS TRUTH HARDWARE AND ITS EMPLOYEES AND THEIR SUCCESSORS AND ASSIGNS FROM AND AGAINST ANY AND ALL CLAIMS, SUITS, LOSSES, DAMAGES OR COSTS INCURRED FROM USING THESE DRAWINGS OR ANY CONTENT THEREOF.

Amesbury Truth
 Equipment Division, Truth Hardware
 700 West Bridge Street
 Owatonna, MN 55060
 Telephone 507-451-5620

THIS DRAWING IS THE PROPERTY OF TRUTH HARDWARE. THE INFORMATION THEREON IS TO BE TREATED AS CONFIDENTIAL. IF IT IS NOT TO BE USED, COPIED, OR DISCLOSED TO OTHER PARTIES, WITHOUT OUR WRITTEN CONSENT.

DRAWN BY: M. NEFF DATE: 11/22/2021
 CHECKED BY: MDN SCALE: 1:4

PART NAME: GENERIC ALUMINUM CONTOUR 55.01